



CHS2 Series Introduction

Revolutionize Energy Storage Solutions

01

CHS2 Introduction

02

Advantage of CHS2

03

Typical Application

04

Case Study

C&I ALL-IN-ONE Hybrid PV ESS Solution



Better Performance

- String current 22.5A, matching high power (210) PV panel
- 6 MPPT, support 200% oversizing
- Adopting C&I 280Ah cell, good performance and higher energy density

Ultimate Safety

- AFCI as standard to prevent fire
- Support core health warning, CO, fire detection, cabinet-level fire protection
- AC and DC type II SPD

Highly Integrated

- pre-installed in the factory, no need for on-site installation and debugging
- Accessing to DG(diesel generator), no need for additional equipment
- AC coupling available

Higher Revenue

- PV and Battery are dc coupled with high efficiency
- Wide environmental adaptability improves VPP revenue
- Intelligent scheduling, and multiple scheduling modes

C&I ALL-IN-ONE Hybrid PV ESS Solution

CB2 Battery Cabinet

CH2 Hybrid Inverter



CHS2-50K-T6-X

Main Configuration

- DC PV Inputs: Max 100kWp
- DC Battery integrated
 - 100.3kWh standard
 - 3 More Battery Cabinets connect with CHS2, means 50kW/400kWh
- AC Output [On Grid]: Max Apparent Power: 55kVA
- AC Output [Back Up]: Support
 - Max output: 55kVA
 - Peak Output: 75kVA for 5s
- AC Output [Diesel Generator]: Support

System Configuration

- Max 10 parallel connection
- Battery capacity: 57kWh-2MWh

C&I ALL-IN-ONE Hybrid PV ESS Solution

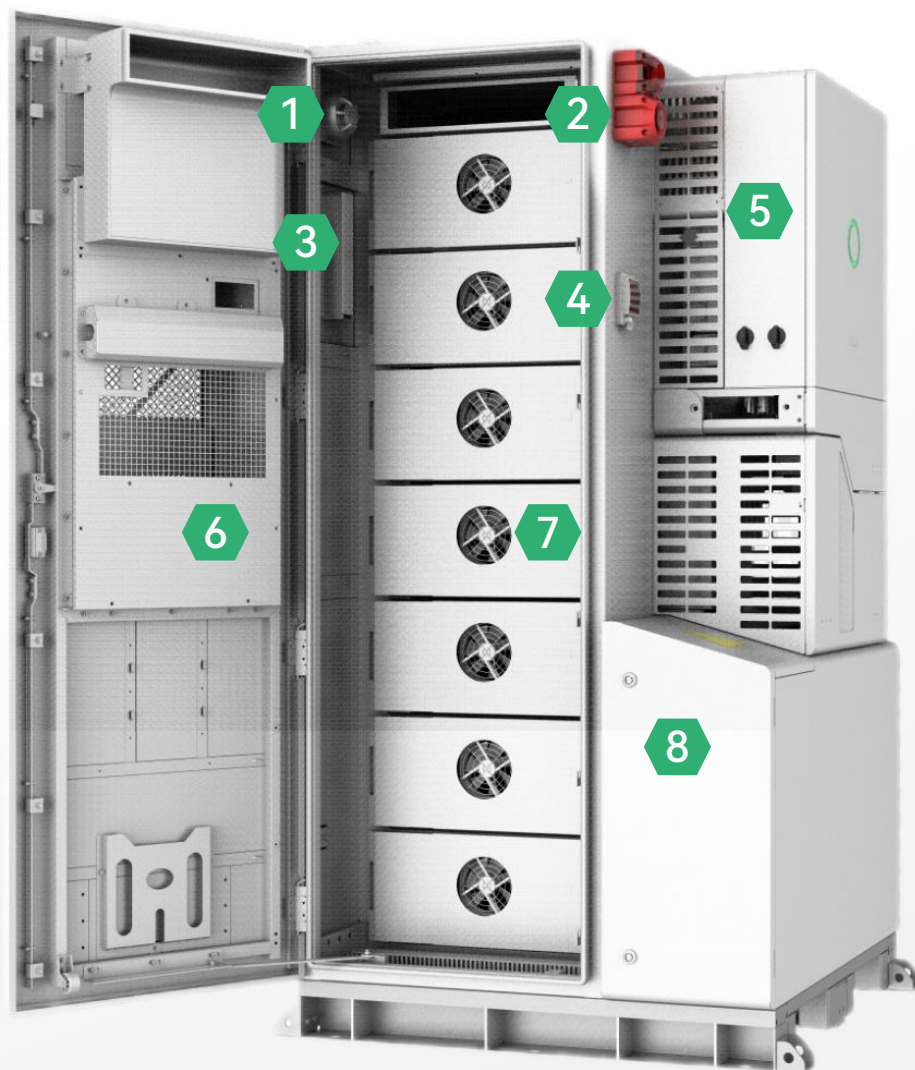

- 1 Smoke\CO\Temperature\Humidity detector
- 2 Sound and light alarms for firefighting
- 3 Aerosol fire extinguishing system
- 4 Emergency stop button
- 5 CH2 hybrid inverter
- 6 Air conditioner
- 7 Battery pack 1P16S 14.3kWh
- 8 Battery high voltage control box

Smart EMS for Multi-Application with CHS2

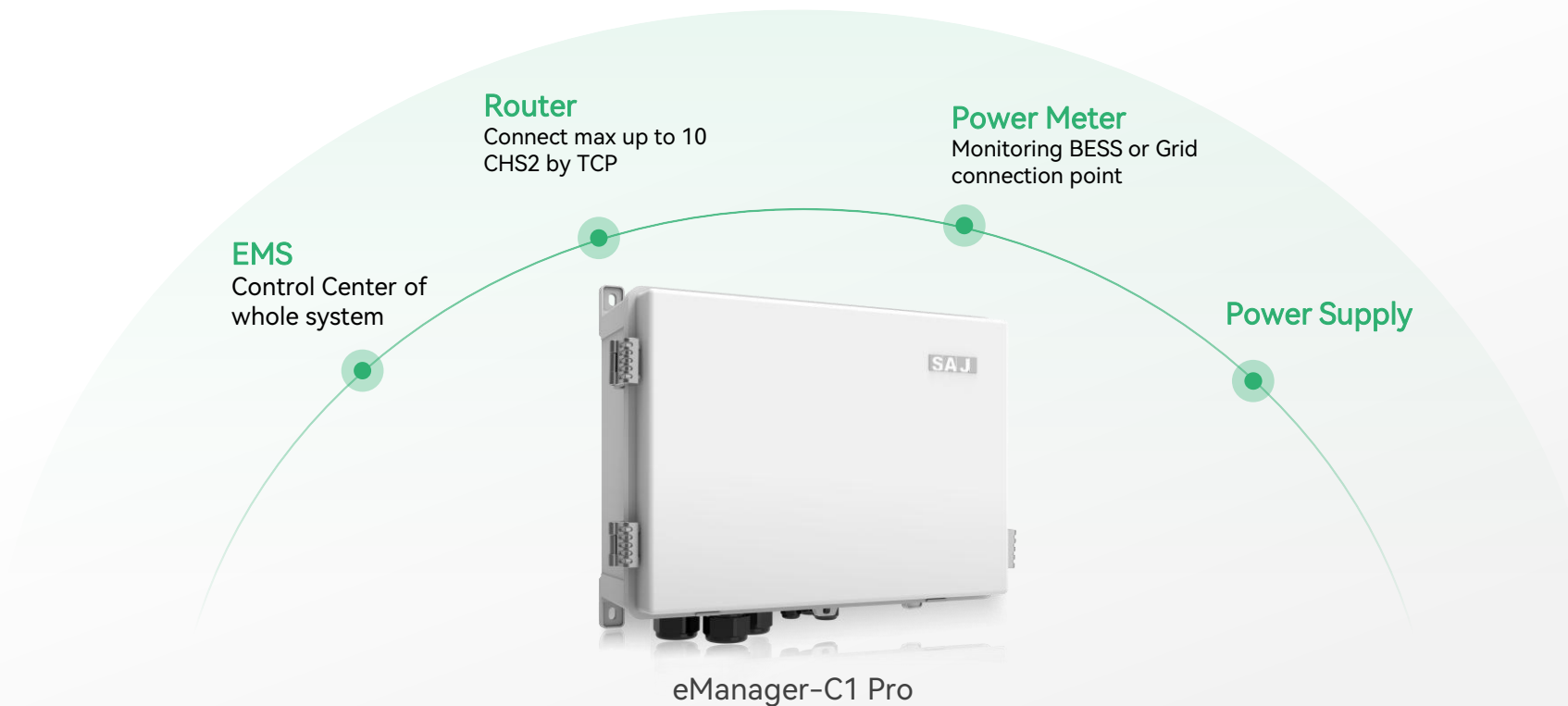

Tips: Max 3 power meter connect for different application scenarios

No	Model	Dedscription
1	eManager-C1 Pro	EMS、Ethernet Switch、Power meter *1 integrated
2	DTSU666 1.5(6)A	2 more meters accesses to EMS supported (grid side and PV inverter side)
3	CTSA024-250A-5A	250A/5A current transformer
4	CTSA035-500A-5A	500A/5A current transformer
5	1000A CT NLH2-0.8 100	1000A/5A current transformer

One for ALL, Multi-Application Support

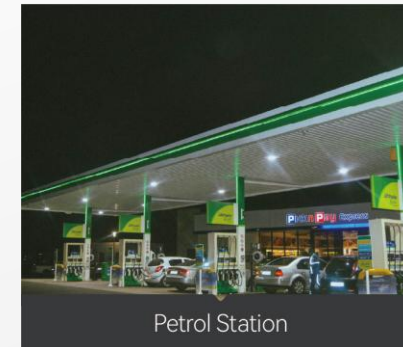
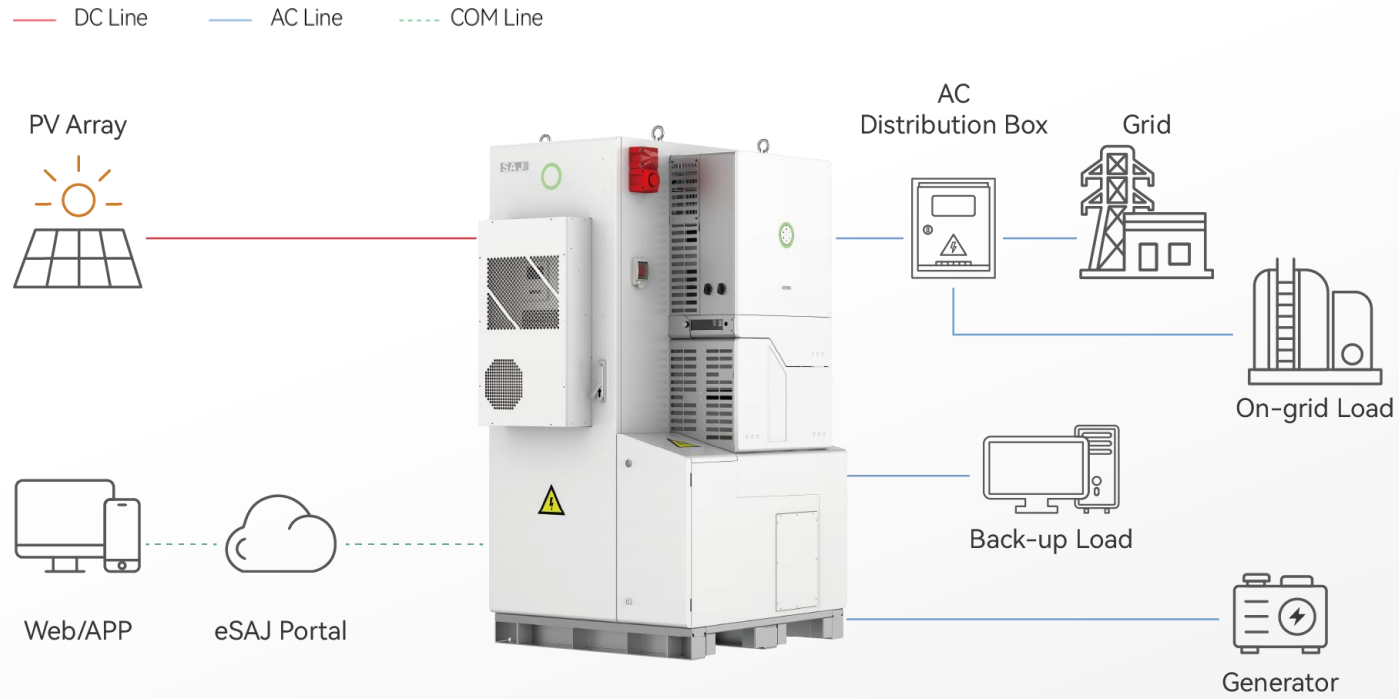

Efficient & Green



Stable & Reliable



Convenient Installation



Multiple Security

01

CHS2 Introduction

02

Advantage of CHS2

03

Typical Application

04

Case Study

Real Backup Ready with 100% Imbalance Loads Support

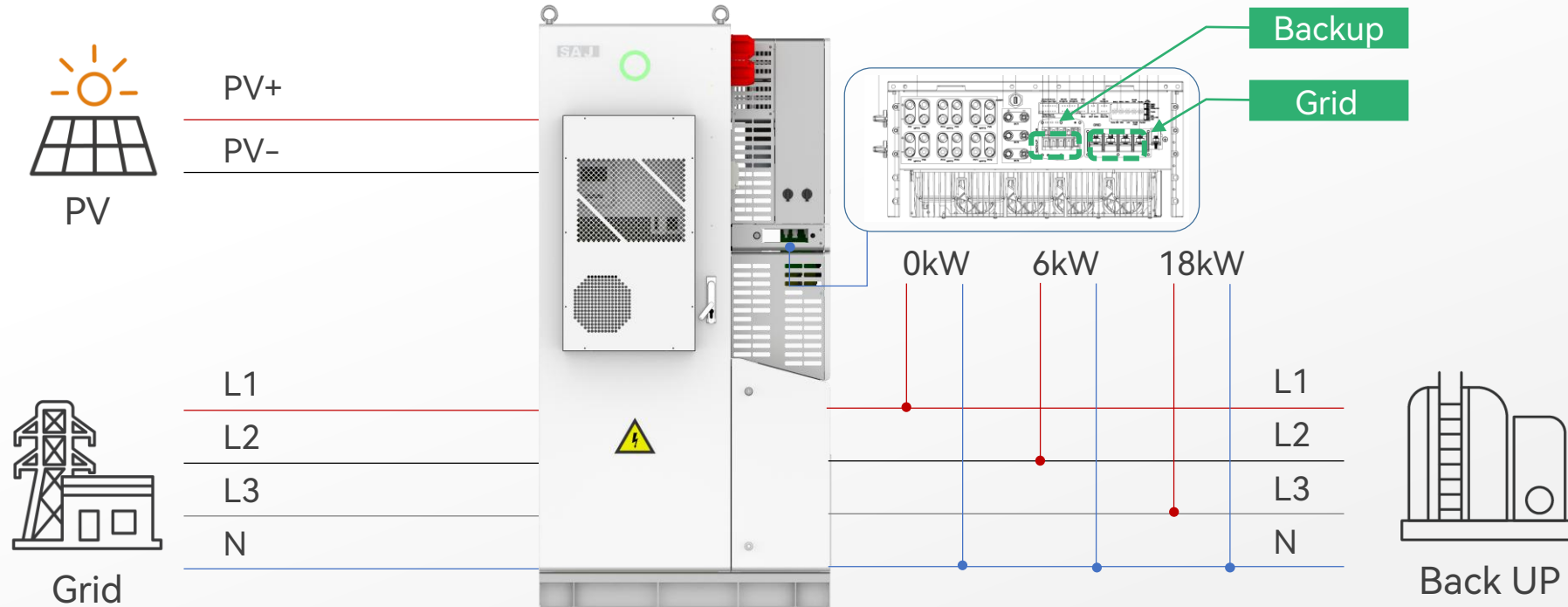

1.5 Times short time overloading

UPS Level On-Off Grid Switch

100% Three Phase Imbalance Loads

* Max 18.3kW load per Phase

Matching the Demands of Electricity Ancillary Services/Trading Market

Renewable energy access exacerbates grid imbalances



Electricity Ancillary Services/ Trading Market are required

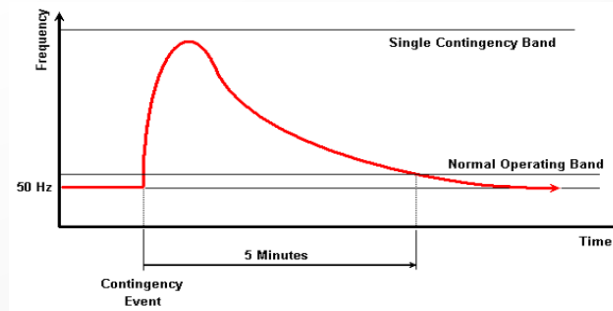

CHS2 Perfect Match it



Smart Air Conditioning

Full Loading Operation in different external ambient temperature



Fast Response

Three-level topology + control algorithm to support fast response



Optimized Configuration

50kW/100kWh standard confi that support much longer time stable full loading output

Electricity Consumption

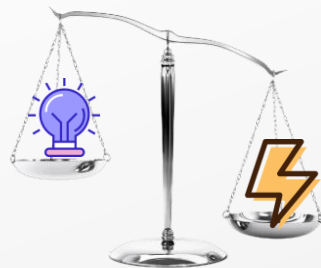

Electricity Generation

Frequency Reserve and Control



Electricity Energy Trading

BESS output curve with SOC

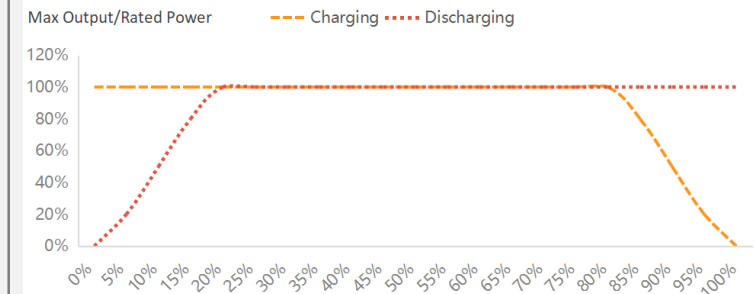

Three Benefits with DC Coupling PV ESS System

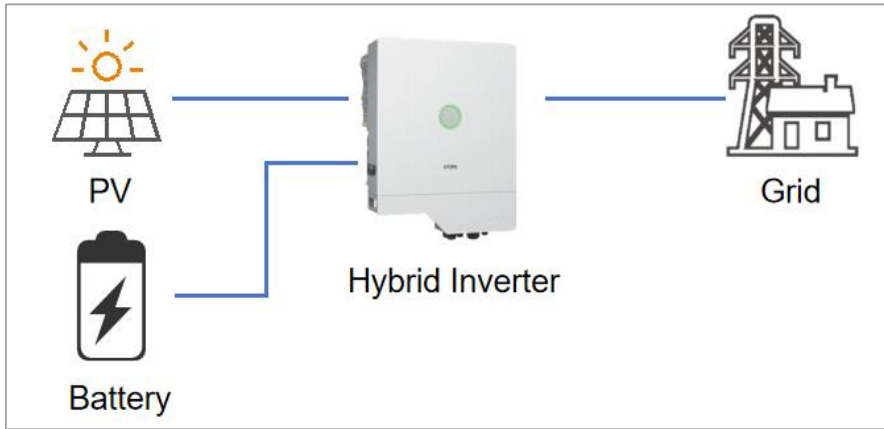

DC Coupling **VS** AC Coupling

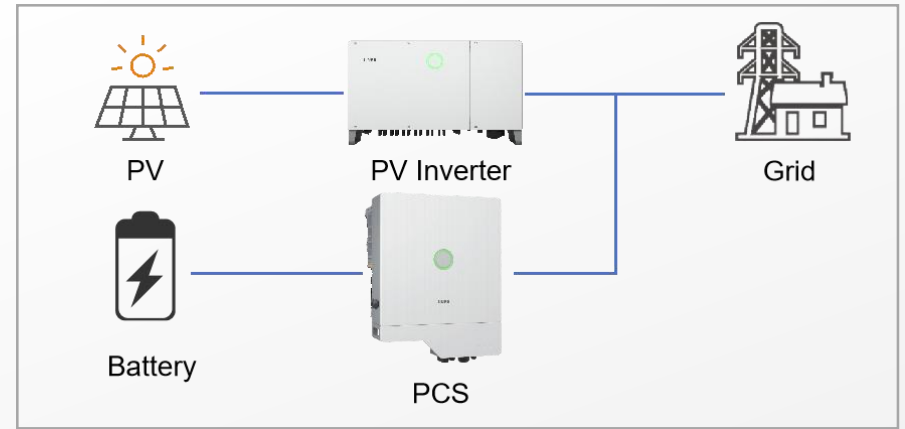

NO.1

Higher Efficiency

- Charing From PV to DC BUS to Battery
Less than 2% Loss

- Charing PV to Inverter to AC Bus to PCS to Battery
At Least 4% Loss

NO.2

Lower Installation Cost

- ALL IN ONE Design,
No more PV inverter and cable

- Inverter and PCS separately Installation
Additional AC Cable connection

NO.3

Saving Grid Demand Capacity

- 50kW PCS+100kWh Battery+100kWp PV
50kW @ Grid Connection Point

- 50kW PCS/100kWh Battery+100kW inverter/100kWp PV
150kW @ Grid Connection Point

54% higher yield with 200% PV Overloading

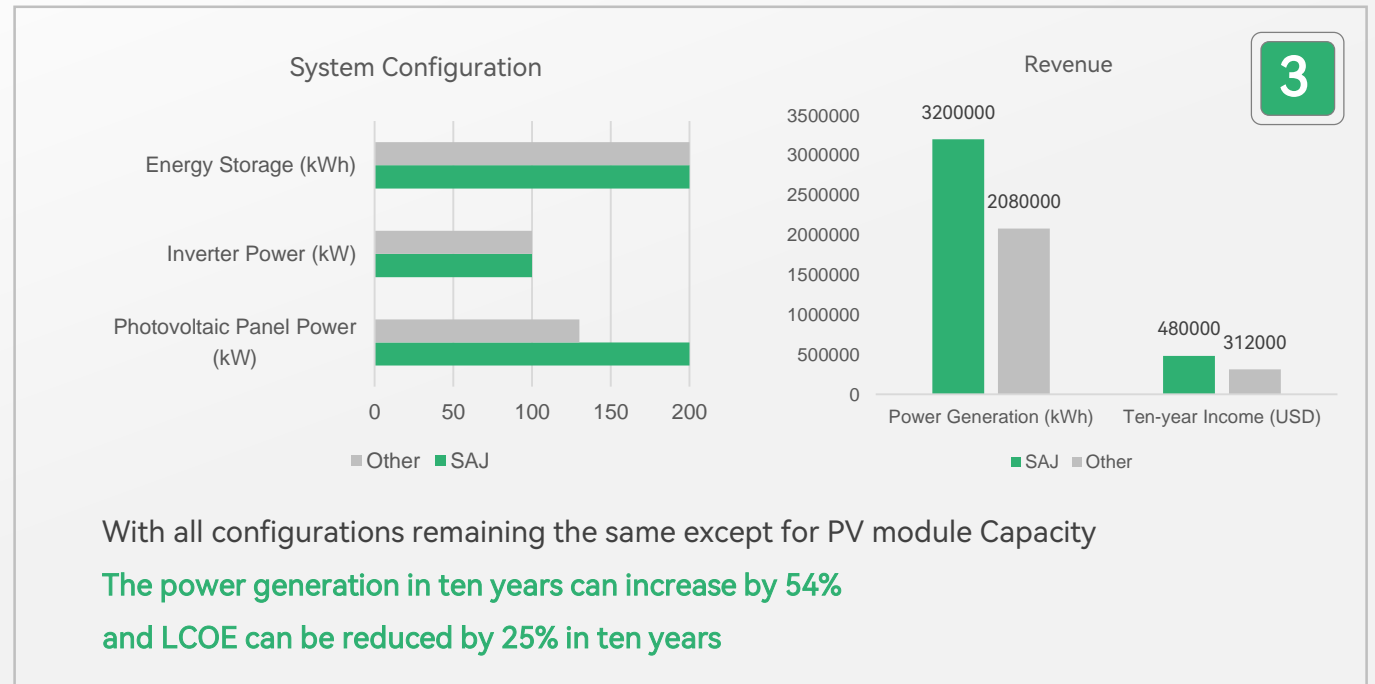
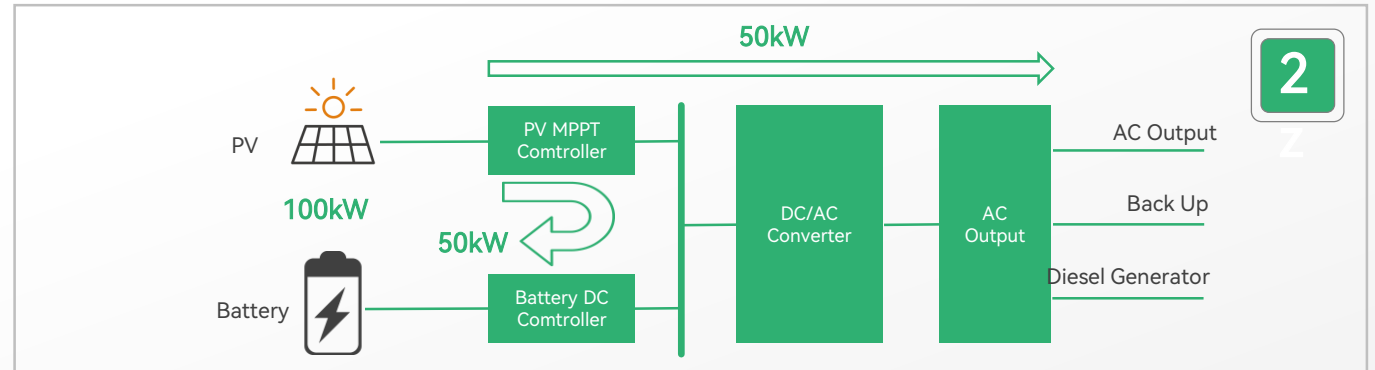
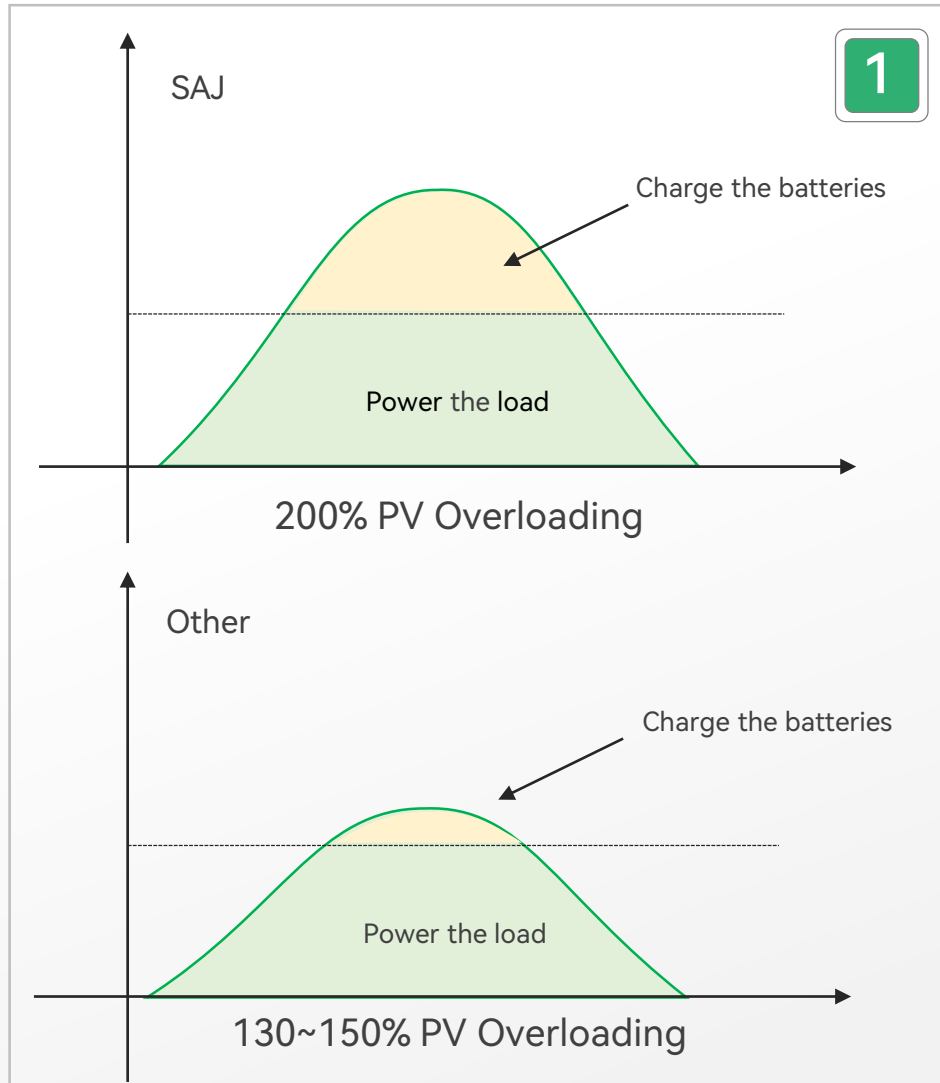

More than 32% Lifetime Throughout Energy with 280Ah Cell

Lifetime Throughout Energy means the total discharge energy during the product life cycle.



	100Ah	280Ah
Battery Type	LFP	LFP
Battery Modular Capacity	5.12kWh	14.3kWh
Battery Module Throughout Energy*	16.1MWh	61MWh
100kWh System Confi	20 Modules	7 Modules
100kWh System Throughout Energy	322MWh	427MWh



Same intial battery installation capacity **32%** more lifetime throughout energy!

* the battery cell lifetime throughout energy come from the parameter of XX module cell manufacture

Up to 4 times the expanded battery capacity

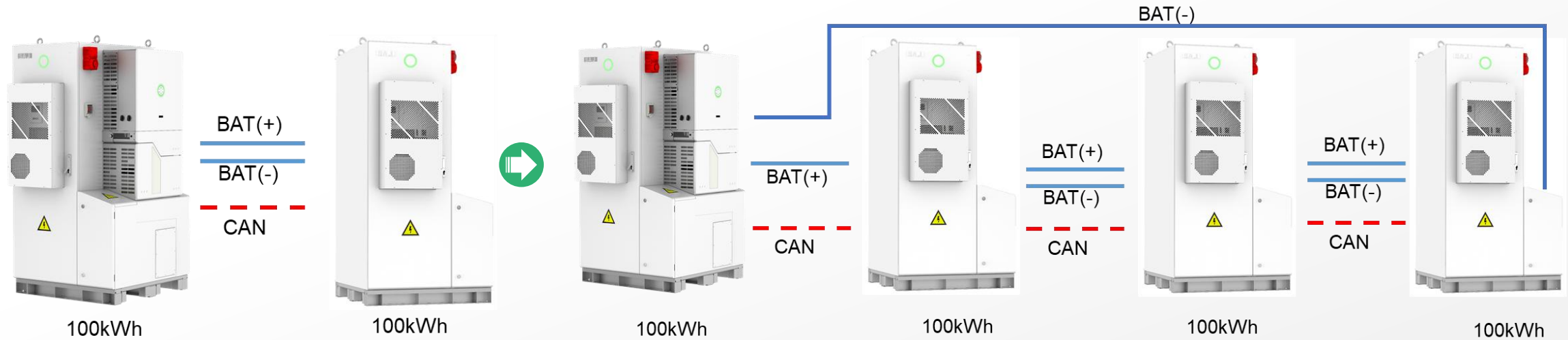

Up to 4 battery cabinets can be coupled to increase the capacity, covering 2h/4h/6h/8h peak hour demand

- The power and communication cables between battery cabinets are not provided in the accessory kit
- The wiring terminals are configured by SAJ
- A single CH2 supports up to 4 CB2 connections

Larger PV Current Inputs and Wider MPPT Range for higher yield

Adapts to complex installation scenarios

- 6MPPT, 200% PV oversizing
- 45 MPPT current
- Low starting-up voltage, wider MPPT voltage range (180-850V) longer power generation time in rainy days and foggy areas.

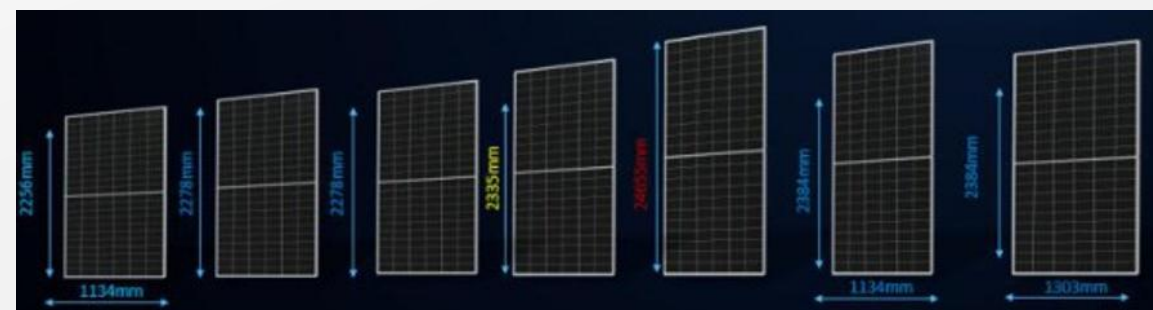
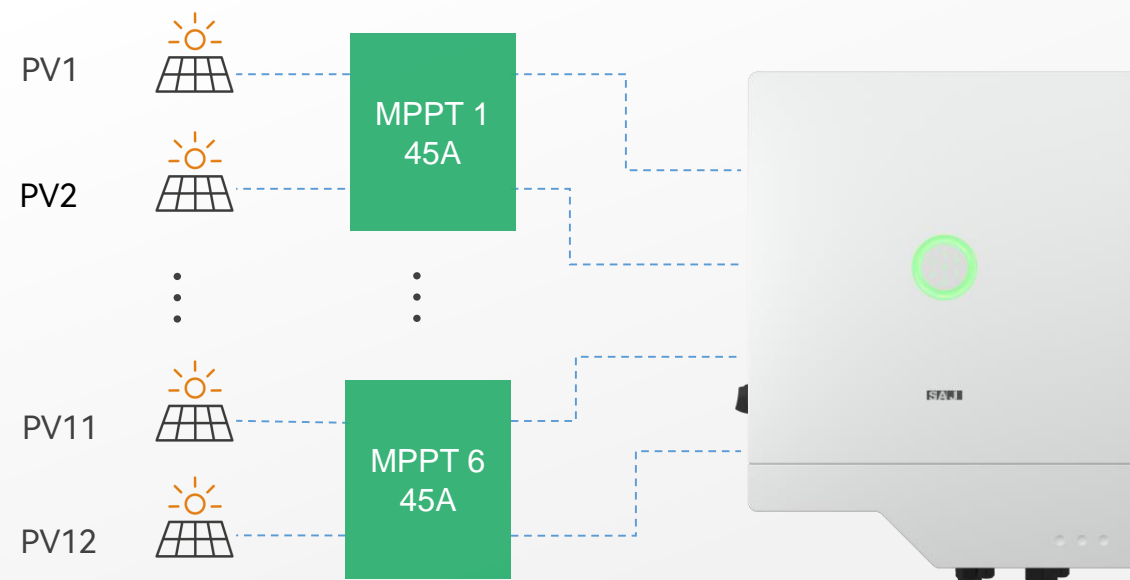

One for All design

Match different size PV modules, Max 22.5A per PV string support

AFCI Integrated, Safe and Reliable

AFCI Support

AFCI reduces the risk of fire

AC and DC type II surge protection

ensures safer and more stable operation on inverter.

IP66 for CH2 inverter and IP55 for CHS2

IP66 protection, compact design, and IP68 fan intelligent air-cooling ensure high reliability and continuous operation of the inverter.



PV+

PV-

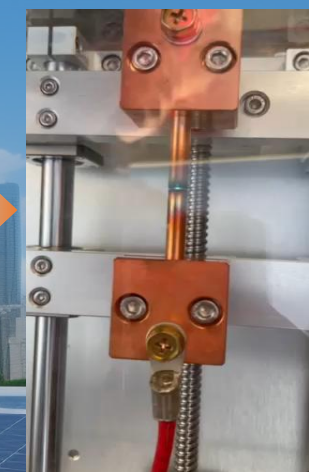

CB2-Battery System Safety Design

6 levels of active/passive fire protection to ensure the safety of customer's property.



ALL IN ONE Design, Plug&Play

All Integrated Before Delivery

Pre-wiring to all components, minimize installation labor costs

Installation

Plug&Play installation on site with DC PV inputs and AC Outputs

Requirement Space

Compact structural design, flexible installation, and maximum utilization of on-site space

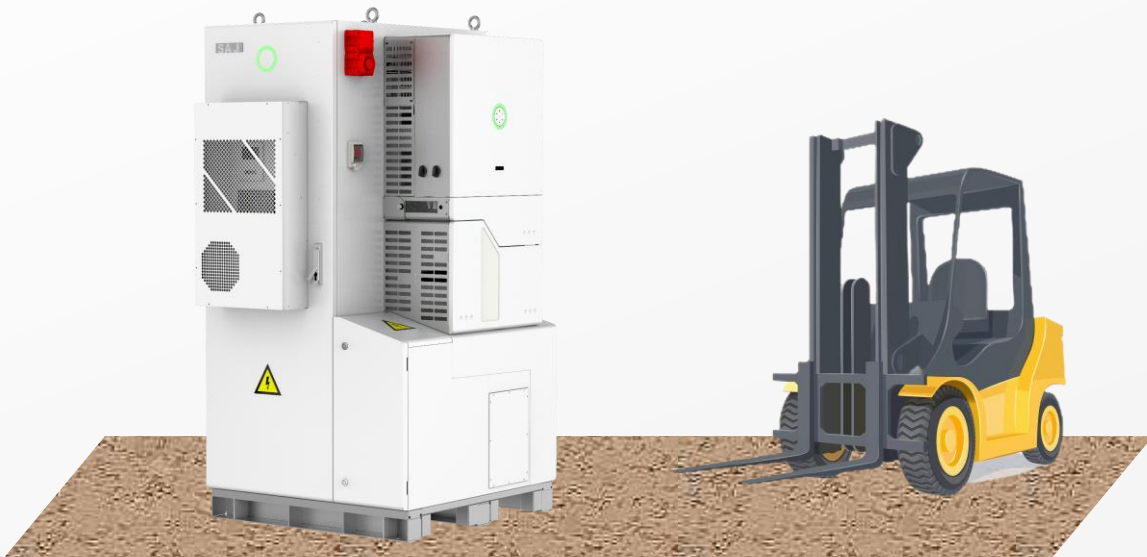

Smart Monitoring and Management System

Plants

Devices

Alarms

Environment

Consumption

Other Data

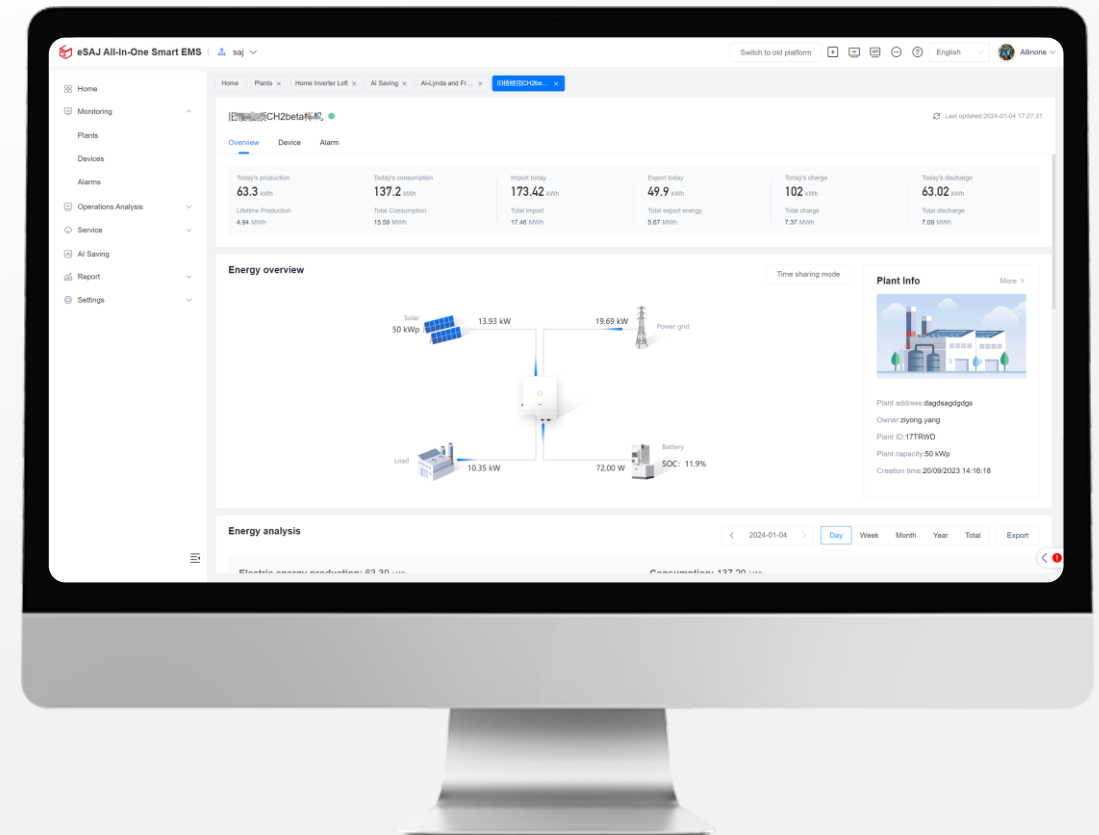
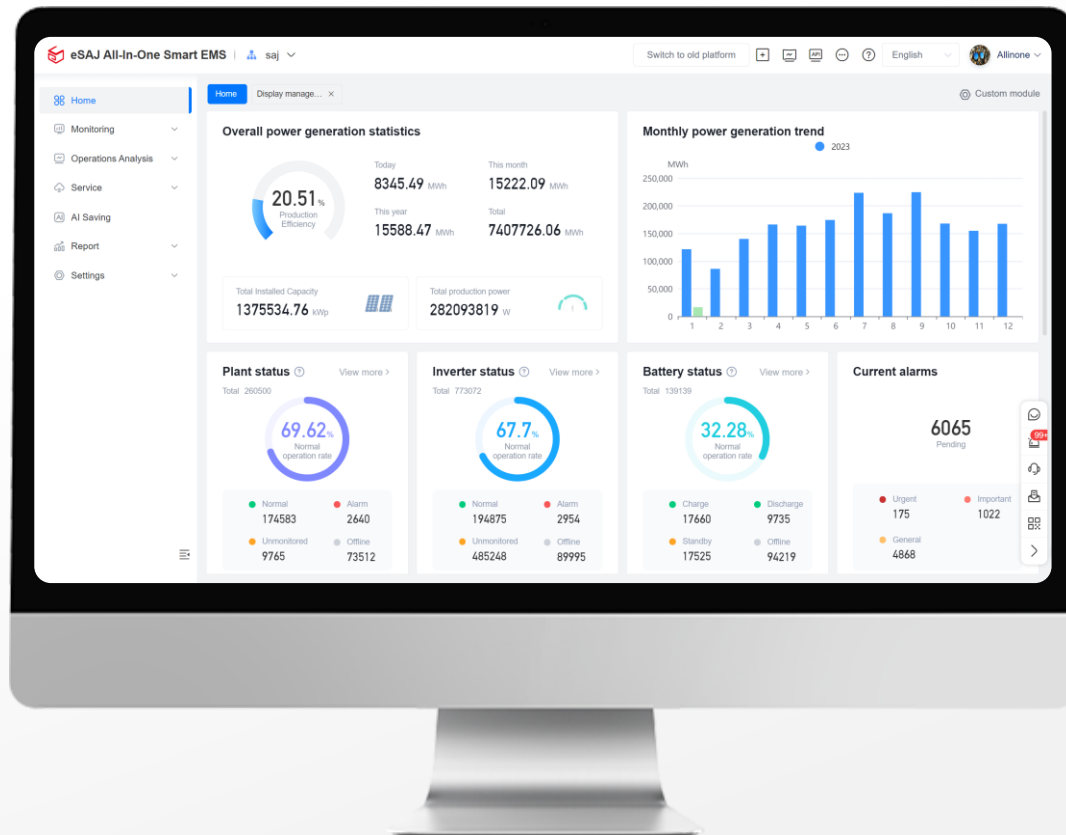

VPP Support for more flexible possibility

VPP: Aggregating residential PV batteries for participation



Energy Aggregators : 5+



Hardware solution

Local gateway of VPP



- High stability
- Quick response



Cloud to cloud solution

API

- Strong compatibility
- Rapid iteration
- Lower costs

SAJ Open Platform



Open IoT Platform

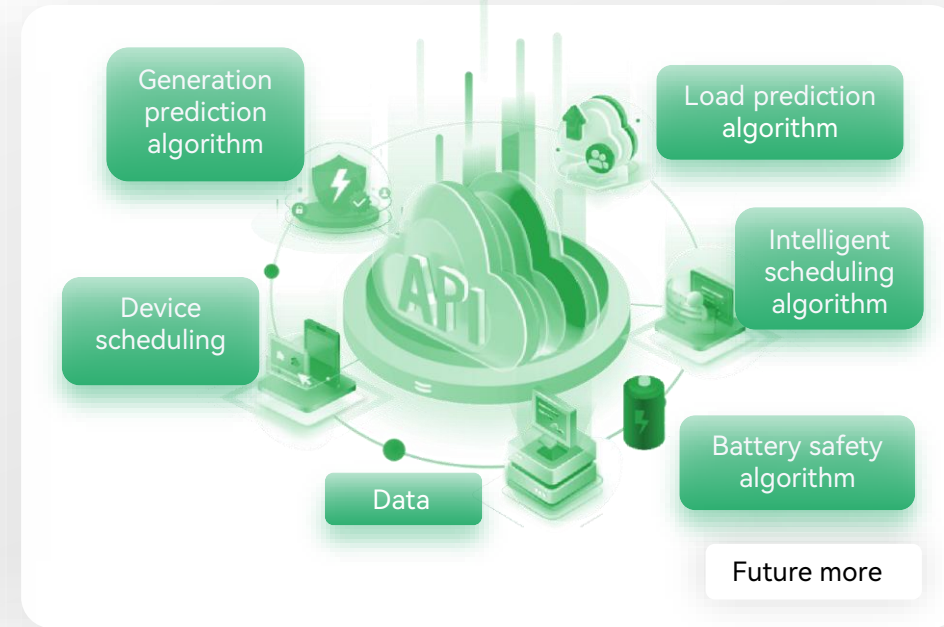
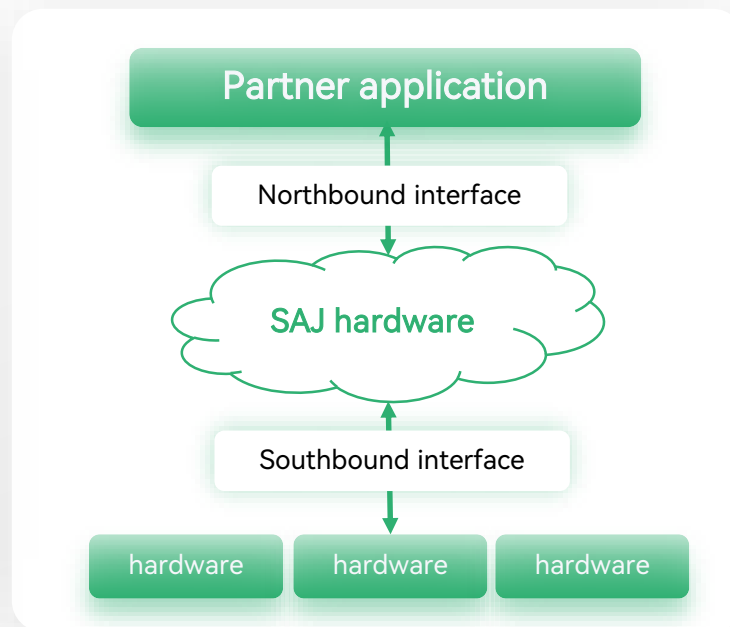
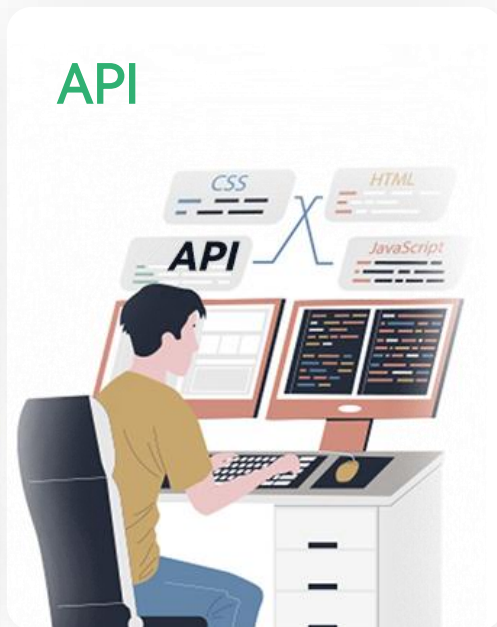

Third-party energy operators

It provides access and control interfaces for energy devices. Energy operators, developers can obtain the ability to interact with energy devices to achieve energy operation scenarios.

Brand partner

Provide the interface of eSAJ Home smart energy management system and other business systems, partners as developers can obtain the ability to interact with the business system, and realize their own more business.

01

CHS2 Introduction

02

Advantage of CHS2

03

Typical Application

04

Case Study

Smart All-In-One Hybrid Solution for C&I Scenarios



Multi Working Model Support

1. Self-Consumption
2. Zero Export
3. Back Up
4. Time of Use
5. Demand Control
6. Passive mode (for grid Auxiliary service)

Typical Application

1. DC coupling On/Off-Grid PV+ESS System
2. AC coupling System
3. Micro grid
4. Power Auxiliary Services (VPP)
5. Agrivoltaic+ESS system

DC Coupling On/Off-Grid PV+ESS System



A one-stop solution for solar power, storage, consumption, and backup power

The PV+ESS supports solar power, energy storage, and seamless switch between on-grid and off-grid operation, ensuring an uninterrupted power supply for users. **During utility grid outages, through rapid and automatic switching to off-grid mode.**

Working mode: Self-consumption / Backup power / Zero export

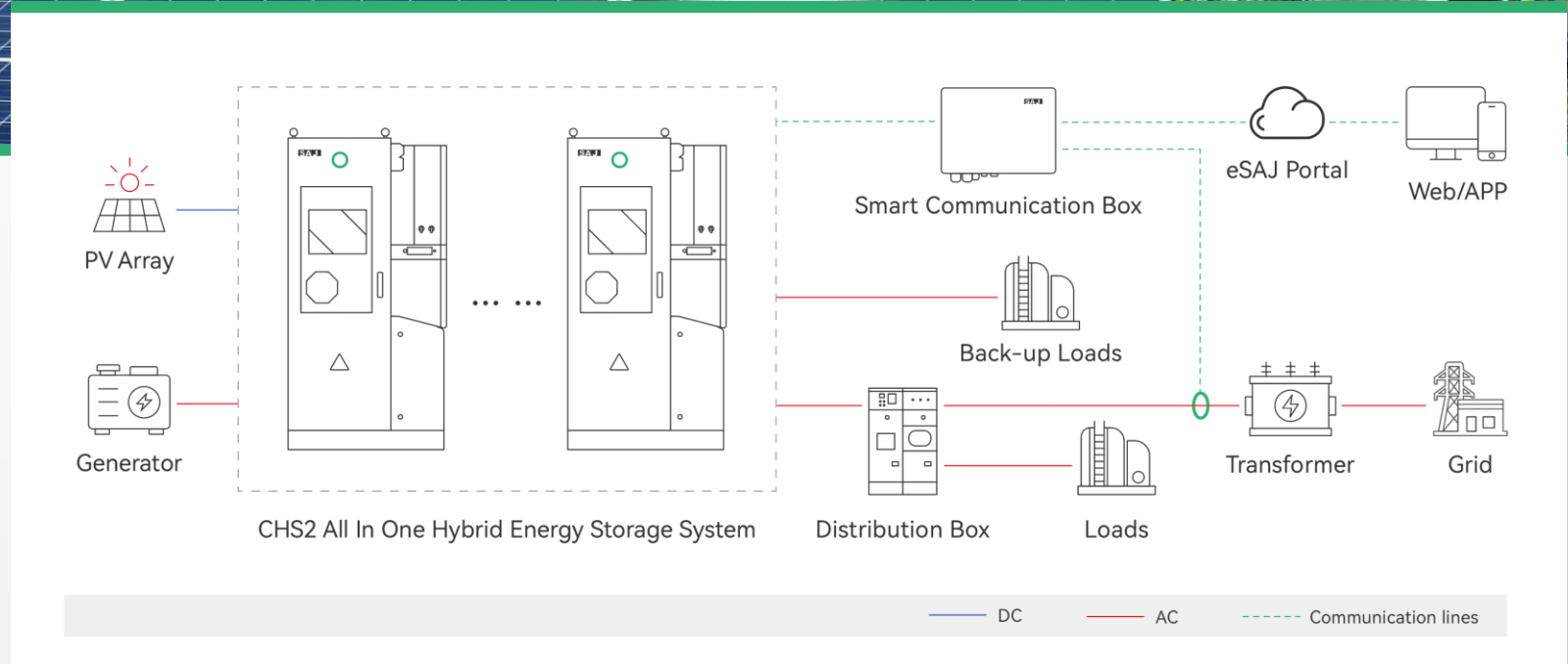

AC Coupling PV+ESS System



Grid congestion solution

The CHS2 can be fed as a buffer by different sources. With the EMS the energy sources can be controlled, but also the consumptions can be switched. For example, when there is a surplus of energy, it is made available to the battery charging. The ESS is AC-coupled with the **PV plants/ wind turbines station/CHP.**

Working mode: Self-consumption / Time of use / Demand Control

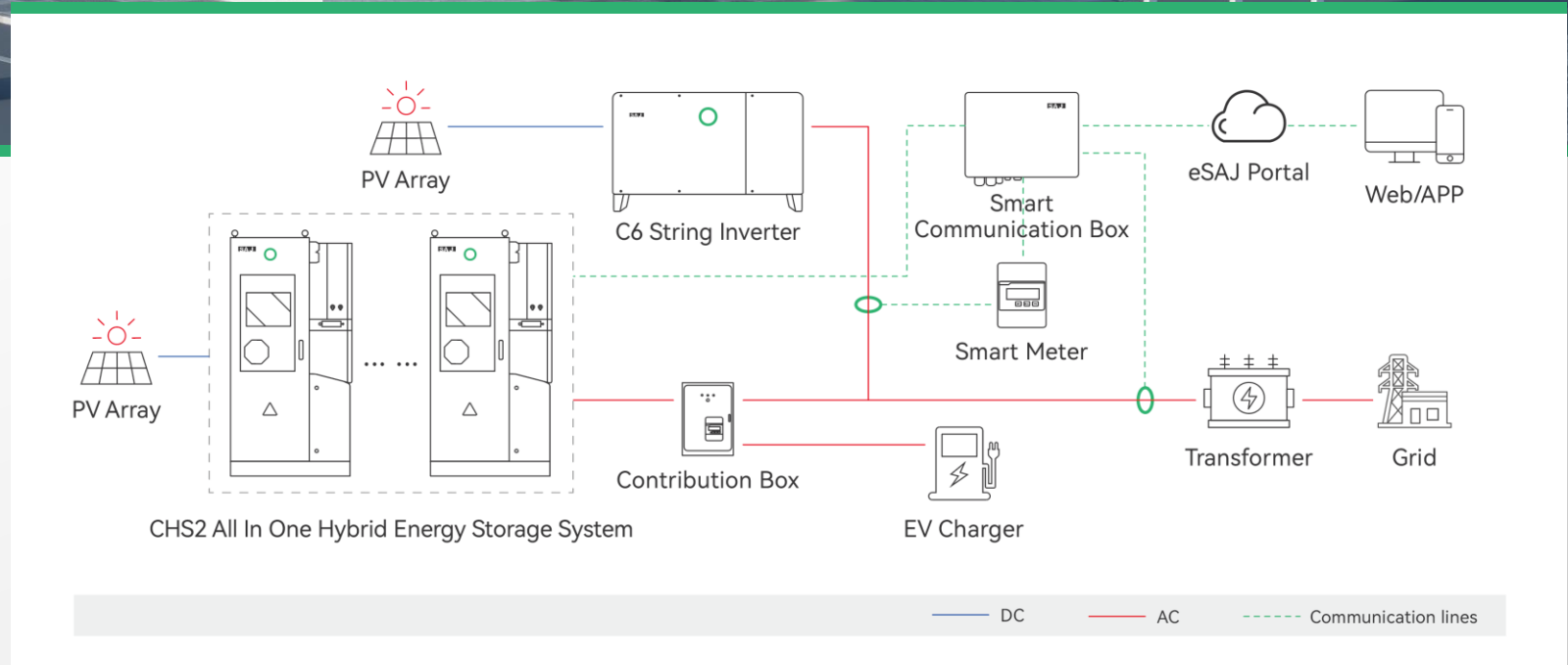

AC Coupling System

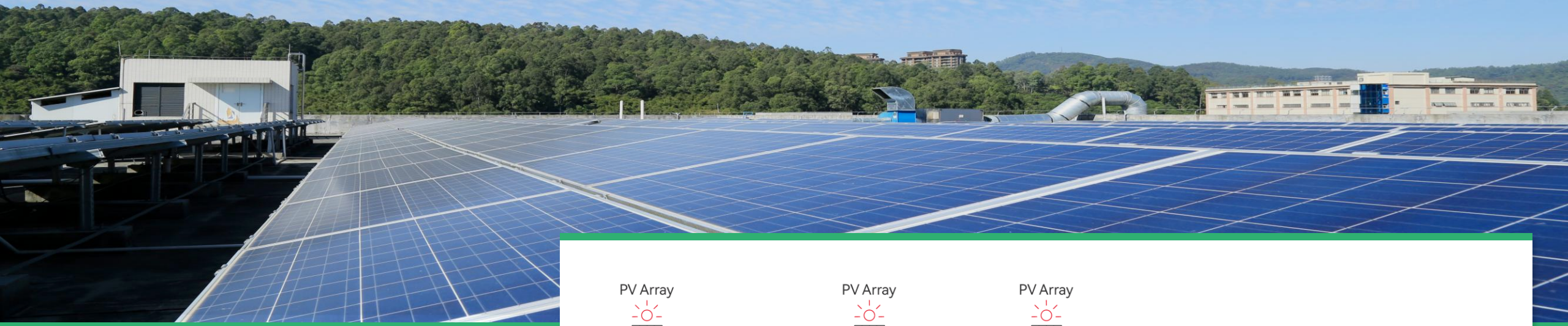

Grid congestion solution

Power boosting , for businesses unable to boost their grid connection power capacity, especially during peak hours, enlarge to a connection **(1~10)x 79.8A**. and a short-term overload current of **(1~10)x 108.75A (5s)**. multiple batteries can be coupled to increase the capacity, covering **2h/4h/6h/8h peak hour demand**.

Working mode: Self-consumption / Time of use / Demand Control

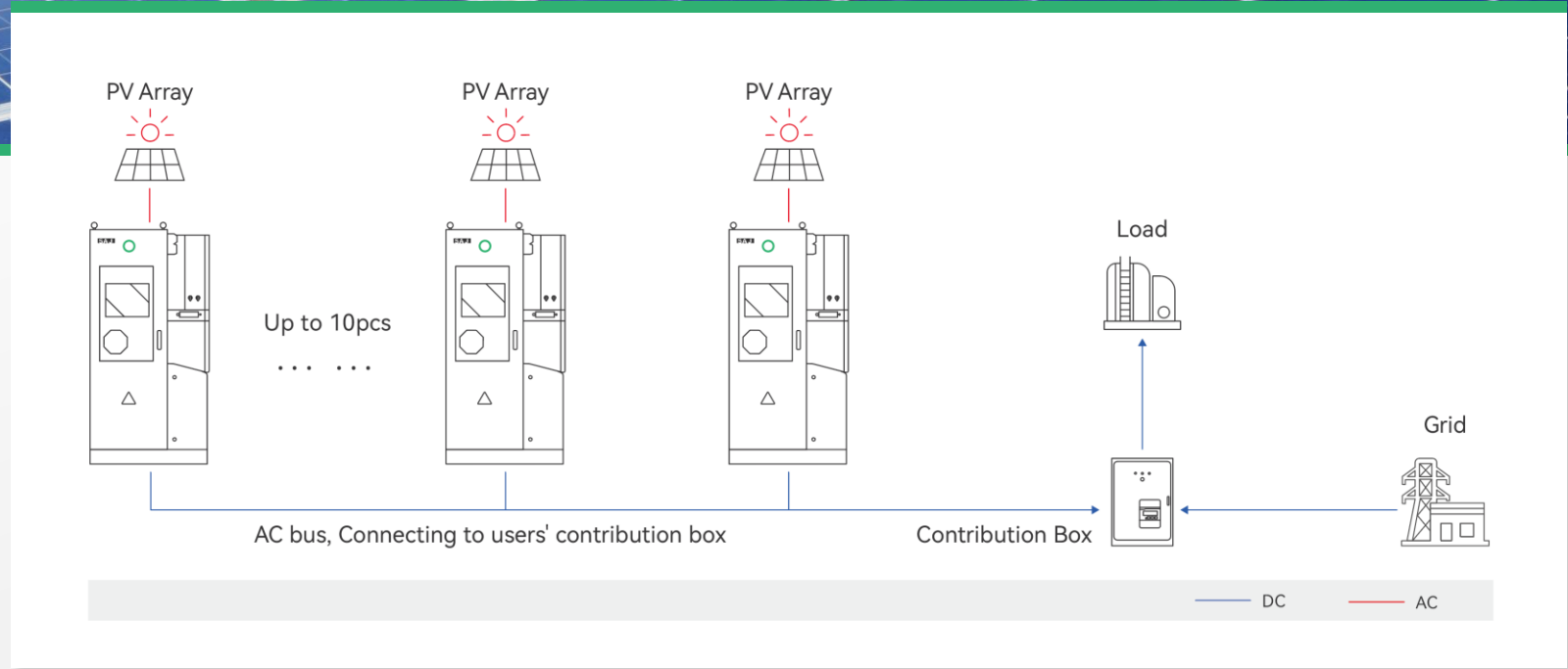

Mico-grid System



Reducing fossil energy consumption and lowering energy costs

In remote areas and on islands without electricity, this system is designed to provide power by coordinating and controlling **the ESS ,PV, and DG (diesel generator)**. **100% three phase off-grid unbalanced output.**

Working mode: Self-consumption

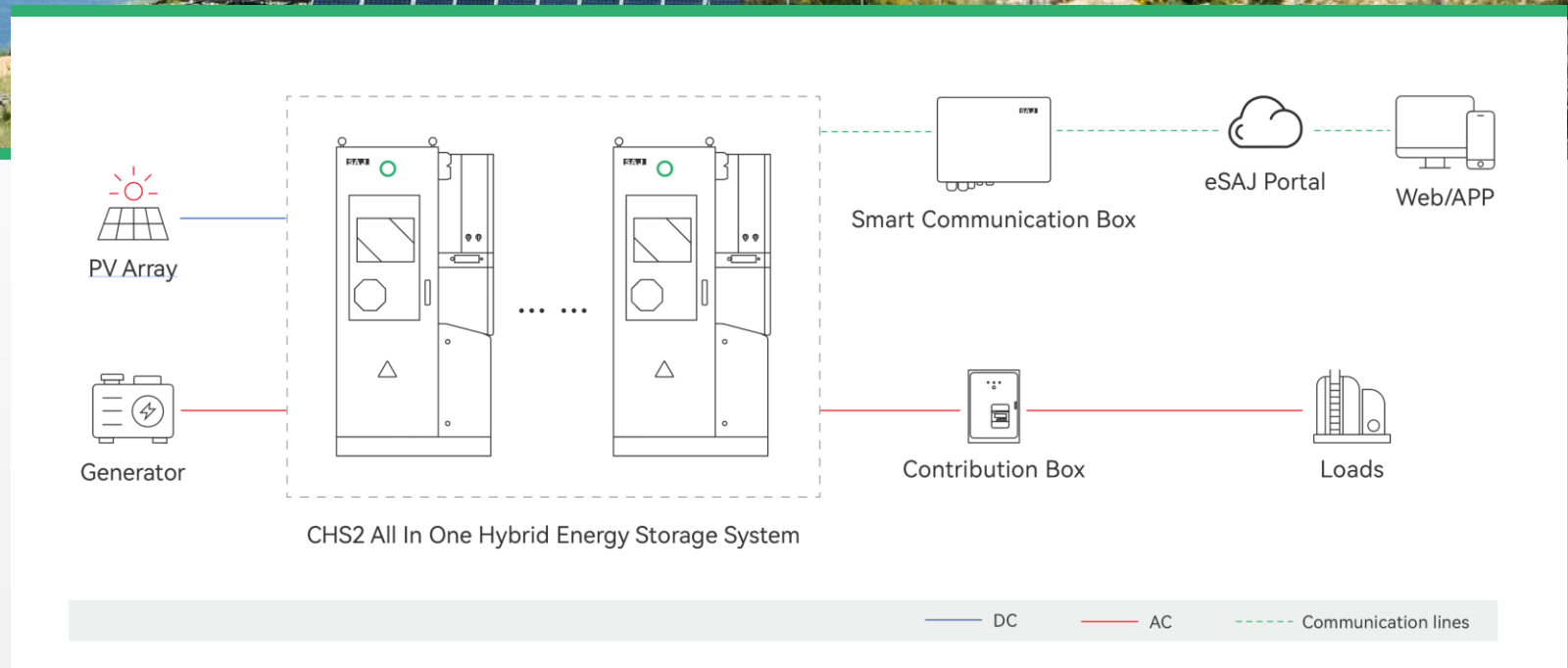

Power Auxiliary Services (VPP)



By connecting to a third-party energy trading platform or through VPP platforms eManager(EMS), eManager can receive and issue dispatch instructions, work with to provide frequency regulation service. **Self-developed core devices, efficient fusion system**, support for Intelligent temperature control system to meet the to ensure stable power output in **adaptability in a wide range of temperature environments**.

Working mode: Passive mode

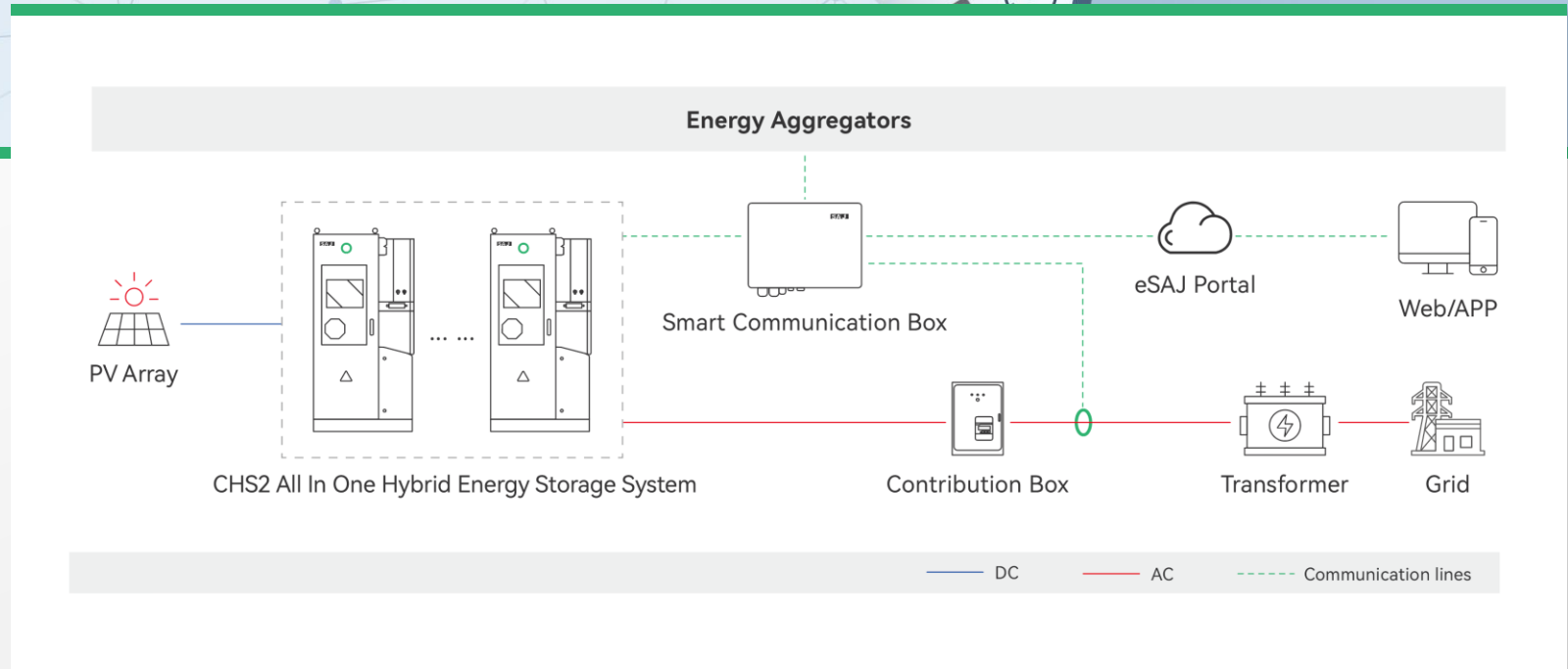

Agrivoltaic+ESS System



Complete solution including PV, ESS and solar water pump.
In areas with unreliable power grids, CHS2 solar storage systems ensure continuous power supply, even off-grid, crucial for protecting agricultural activities from power-related disruptions and financial losses. Empowering farmers with a complete range of renewable energy solutions.

Working mode: Self-consumption

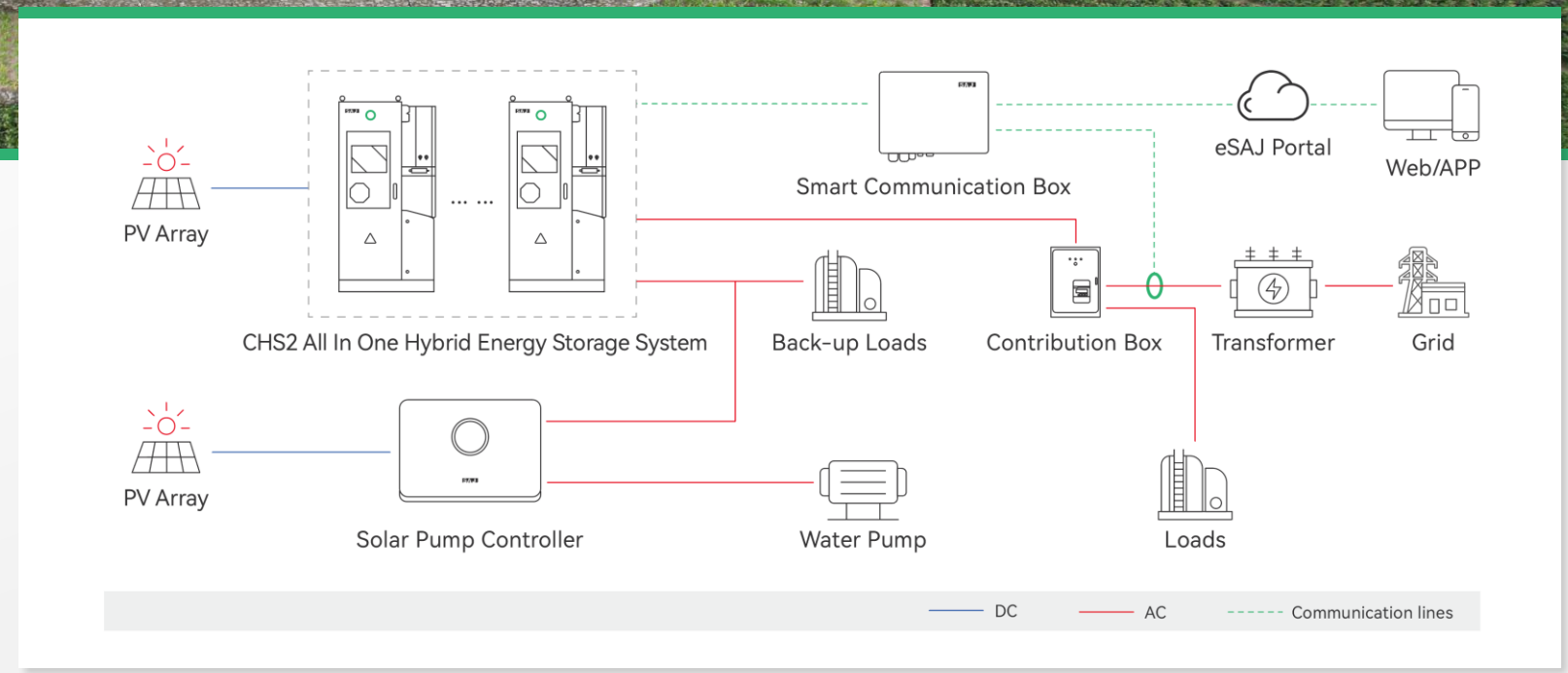

01

CHS2 Introduction

02

Advantage of CHS2

03

Typical Application

04

Case Study

Smart Solar Energy Storage Solution Project 50kW/100kWh

Northern Cape, South Africa



Background

Nutlink Farm is a well-known agricultural establishment dedicated to the cultivation of pecan nut trees in South Africa. With 5,000 pecan nut trees under its care

Challenge

The farm encounters significant challenges during the harvest season. Load-shedding more than 1900 hours in 2022 resulted in 65% pecan nut reduction

Solution

CHS2 solution enables simultaneous power supply and reduce reliance on the grid with a professional commercial energy storage system that includes 50% more photovoltaic modules than the industry average.

Annual power generated : **10MW+h**

Carbon reduced: **80+tons CO²**



DC coupling PV+ESS project 50kW/100kWh

Melbourne, Australia



Background

The building serves as a warehouse for a solar energy company. There is a high volume of goods being transported through the warehouse every day. The busy operations result in an increasing demand for electricity.

Challenge

It requires a lot of energy to lift the heavy goods, for both morning and nighttime operations. However, a significant amount of solar power is wasted during midday.

Solution

The PV installation generates green electricity right on top of the building. The CHS2 solution ensures the best use of this power and also smooths the peak loads for the power drawn from the grid.



THANK YOU

Revolutionize Energy Storage Solutions

Guangzhou Sanjing Electric Co., Ltd.

Add: No.9, Lizhishan Road, Science City, Guangzhou High-tech Zone, Guangdong, P.R.China

Tel: 400-960-0112 Fax: 020-66608589 Web: www.saj-electric.com

